

## Transient Voltage Suppressors (TVS) Data Sheet

### Features

- Glass passivated junction
- Low incremental surge resistance.
- Excellent clamping capability
- 5000W peak pulse power capability at 10/1000 $\mu$ s waveform, repetition rate (duty cycle): 0.05%
- Fast response time
- Typical  $I_R$  less than 2 $\mu$ A above 10V.
- High Temperature soldering guaranteed: 265 $^{\circ}$ C/10 seconds/.375", (9.5mm) lead length, 5lbs (2.3kg) tension
- Plastic package has underwriters laboratory flammability 94V-0
- Meets MSL level 1, per J-STD-020.
- AEC-Q101 qualified (Automotive grade with suffix "Q".)
- Expsemi electronics
- UL Certification:E492977



### Mechanical Data

- Case: Moulded plastic over glass passivated junction
- Terminal: Plated Axial leads, solderable per MIL-STD-750, Method 2026
- Polarity: Color band denotes cathode except bi-directional models
- Mounting Position: Any

### Applications

- AC/DC power supply
- I/O interface
- Low frequency signal transmission line

### Maximum Ratings and Characteristics

Ratings at 25 $^{\circ}$ C ambient temperature unless otherwise specified.

Rating	Symbol	Value	Units
Peak pulse power dissipation at 10/1000 $\mu$ s waveform (Note1, Fig.1)	$P_{PPM}$	Minimum 5000	Watts
Peak pulse current of at 10/1000 $\mu$ s waveform (Note 1, Fig.3)	$I_{PPM}$	See Table	Amps
Steady state power dissipation at $T_L=75^{\circ}$ C (Fig.5)	$P_{M(AV)}$	8.0	Watts
Peak forward surge current, 8.3ms single half sine-wave superimposed on rated load, (JEDEC Method) (Note2, Fig.6)	$I_{FSM}$	400	Amps
Operating junction and Storage Temperature Range.	$T_J, T_{STG}$	-55 to +175	$^{\circ}$ C
Typical thermal resistance junction to lead	$R_{\theta JL}$	8	$^{\circ}$ C/W
Typical thermal resistance junction to ambient	$R_{\theta JA}$	40	$^{\circ}$ C/W

Notes: 1. Non-repetitive current pulse, per Fig.3 and derated above  $T_A=25^{\circ}$ C per Fig.2.

2. 8.3ms single half sine-wave, or equivalent square wave, duty cycle=4 pulses per minutes maximum.

**Dimensions (P600)**

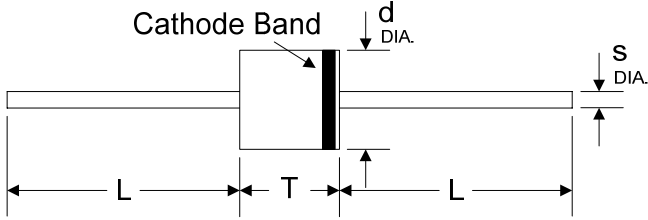
	Symbol	Millimeters		Inches	
		Min.	Max.	Min.	Max.
	L	25.40	-	1.000	-
	T	8.60	9.10	0.340	0.360
	d	8.60	9.10	0.340	0.360
s	1.19	1.32	0.047	0.052	

**Electrical Characteristics ( $T_A=25^\circ\text{C}$ )**

Part Number		Reverse Stand-Off Voltage	Breakdown Voltage @ $I_T$	Test Current	Maximum Clamping Voltage @ $I_{PP}$	Peak Pulse Current	Reverse Leakage @ $V_{RWM}$
Unidirectional	Bidirectional	$V_{RWM}(V)$	$V_{BR}(V)$	$I_T(mA)$	$V_C(V)$	$I_{PP}(A)$	$I_R(\mu A)$
5KP5.0A	5KP5.0CA	5.0	6.40~7.00	50	9.2	554.3	5000
5KP6.0A	5KP6.0CA	6.0	6.67~7.37	50	10.3	495.1	5000
5KP6.5A	5KP6.5CA	6.5	7.22~7.98	50	11.2	455.4	2000
5KP7.0A	5KP7.0CA	7.0	7.78~8.60	50	12.0	425.0	1000
5KP7.5A	5KP7.5CA	7.5	8.33~9.21	5	12.9	395.3	250
5KP8.0A	5KP8.0CA	8.0	8.89~9.83	5	13.6	375.0	150
5KP8.5A	5KP8.5CA	8.5	9.44~10.40	5	14.4	354.2	50
5KP9.0A	5KP9.0CA	9.0	10.00~11.10	5	15.4	331.2	20
5KP10A	5KP10CA	10.0	11.10~12.30	5	17.0	300.0	15
5KP11A	5KP11CA	11.0	12.20~13.50	5	18.2	280.2	2
5KP12A	5KP12CA	12.0	13.30~14.70	5	19.9	256.3	2
5KP13A	5KP13CA	13.0	14.40~15.90	5	21.5	237.2	2
5KP14A	5KP14CA	14.0	15.60~17.20	5	23.2	219.8	2
5KP15A	5KP15CA	15.0	16.70~18.50	5	24.4	209.0	2
5KP16A	5KP16CA	16.0	17.80~19.70	5	26.0	196.2	2
5KP17A	5KP17CA	17.0	18.90~20.90	5	27.6	184.8	2
5KP18A	5KP18CA	18.0	20.00~22.10	5	29.2	174.7	2
5KP20A	5KP20CA	20.0	22.20~24.50	5	32.4	157.4	2
5KP22A	5KP22CA	22.0	24.40~26.90	5	35.5	143.7	2
5KP24A	5KP24CA	24.0	26.70~29.50	5	38.9	131.1	2
5KP26A	5KP26CA	26.0	28.90~31.90	5	42.1	121.1	2

**Electrical Characteristics (T<sub>A</sub>=25°C)**

Part Number		Reverse Stand-Off Voltage	Breakdown Voltage @I <sub>T</sub>	Test Current	Maximum Clamping Voltage @I <sub>PP</sub>	Peak Pulse Current	Reverse Leakage @V <sub>RWM</sub>
Unidirectional	Bidirectional	V <sub>RWM</sub> (V)	V <sub>BR</sub> (V)	I <sub>T</sub> (mA)	V <sub>C</sub> (V)	I <sub>PP</sub> (A)	I <sub>R</sub> (μA)
5KP28A	5KP28CA	28.0	31.10~34.40	5	45.4	112.3	2
5KP30A	5KP30CA	30.0	33.30~36.80	5	48.4	105.4	2
5KP33A	5KP33CA	33.0	36.70~40.60	5	53.3	95.7	2
5KP36A	5KP36CA	36.0	40.00~44.20	5	58.1	87.8	2
5KP40A	5KP40CA	40.0	44.40~49.10	5	64.5	79.1	2
5KP43A	5KP43CA	43.0	47.80~52.80	5	69.4	73.5	2
5KP45A	5KP45CA	45.0	50.00~55.30	5	72.7	70.2	2
5KP48A	5KP48CA	48.0	53.30~58.90	5	77.4	65.9	2
5KP51A	5KP51CA	51.0	56.70~62.70	5	82.4	61.9	2
5KP54A	5KP54CA	54.0	60.00~66.30	5	87.1	58.6	2
5KP58A	5KP58CA	58.0	64.40~71.20	5	93.6	54.5	2
5KP60A	5KP60CA	60.0	66.70~73.70	5	96.8	52.7	2
5KP64A	5KP64CA	64.0	71.10~78.60	5	103.0	49.5	2
5KP70A	5KP70CA	70.0	77.80~86.00	5	113.0	45.1	2
5KP75A	5KP75CA	75.0	83.30~92.10	5	121.0	42.1	2
5KP78A	5KP78CA	78.0	86.70~95.80	5	126.0	40.5	2
5KP85A	5KP85CA	85.0	94.40~104.00	5	137.0	37.2	2
5KP90A	5KP90CA	90.0	100.00~111.00	5	146.0	34.9	2
5KP100A	5KP100CA	100.0	110.00~123.00	5	162.0	31.5	2
5KP110A	5KP110CA	110.0	122.00~135.00	5	177.0	28.8	2
5KP120A	5KP120CA	120.0	133.00~147.00	5	193.0	26.4	2
5KP130A	5KP130CA	130.0	144.00~159.00	5	209.0	24.4	2
5KP150A	5KP150CA	150.0	167.00~185.00	5	243.0	21.0	2
5KP160A	5KP160CA	160.0	178.00~197.00	5	259.0	19.7	2
5KP170A	5KP170CA	170.0	189.00~209.00	5	275.0	18.5	2
5KP180A	5KP180CA	180.0	201.00~222.00	5	292.0	17.5	2
5KP190A	5KP190CA	190.0	211.00~233.00	5	310.0	16.5	2
5KP200A	5KP200CA	200.0	224.00~247.00	5	329.2	15.5	2
5KP210A	5KP210CA	210.0	237.00~263.00	5	349.5	14.6	2
5KP220A	5KP220CA	220.0	246.00~272.00	5	371.1	13.7	2
5KP250A	5KP250CA	250.0	277.00~306.00	5	425.0	12.0	2

Notes: For bidirectional type having V<sub>RWM</sub> of 10V and less, the I<sub>R</sub> limit is double.

Ratings and Characteristic Curves ( $T_A=25^{\circ}\text{C}$  unless otherwise noted)

Figure 1. Peak Pulse Power Rating Curve

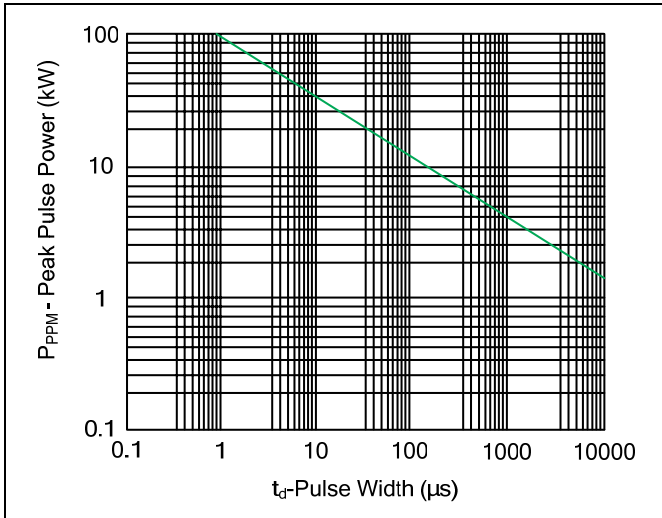

Figure 2. Pulse Derating Curve

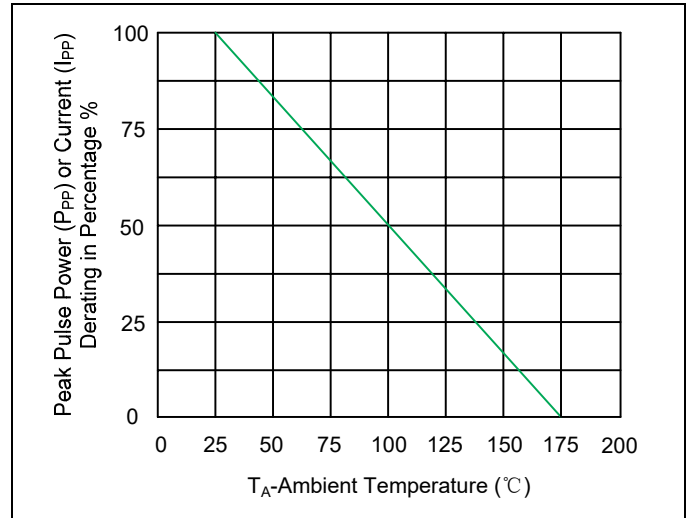

Figure 3. Pulse Waveform

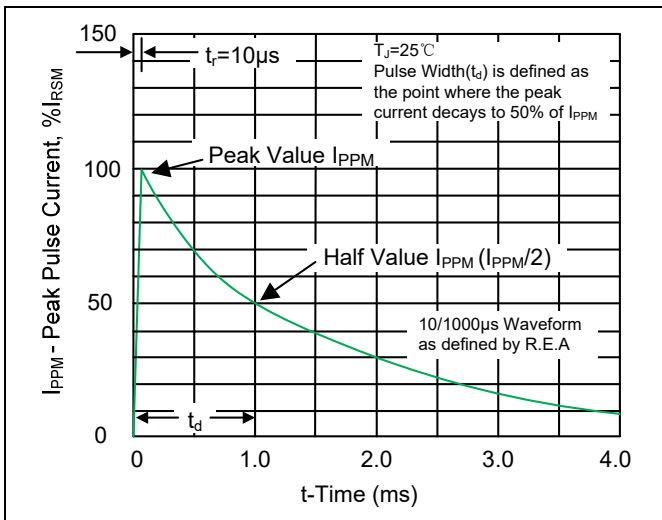

Figure 4. Typical Junction Capacitance

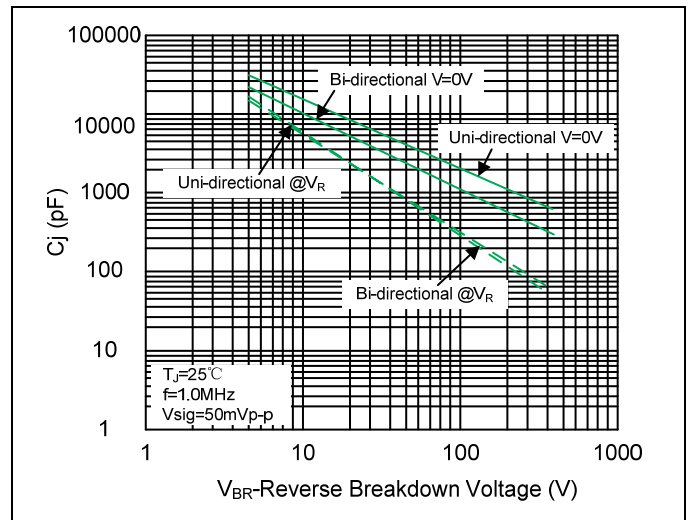

Figure 5. Steady State Power Dissipation Derating Curve

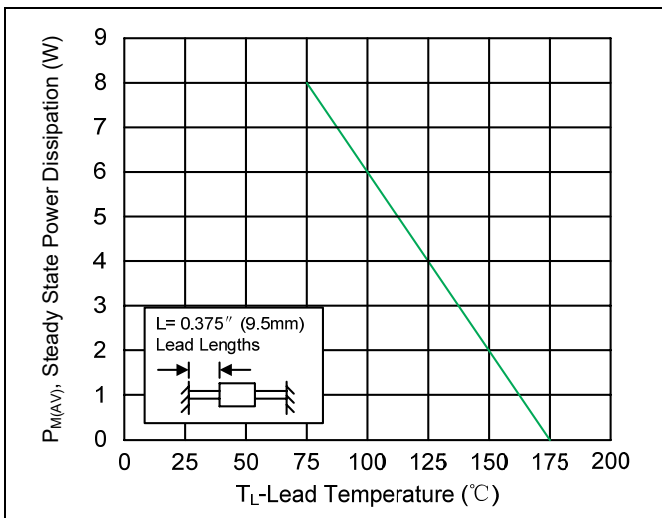
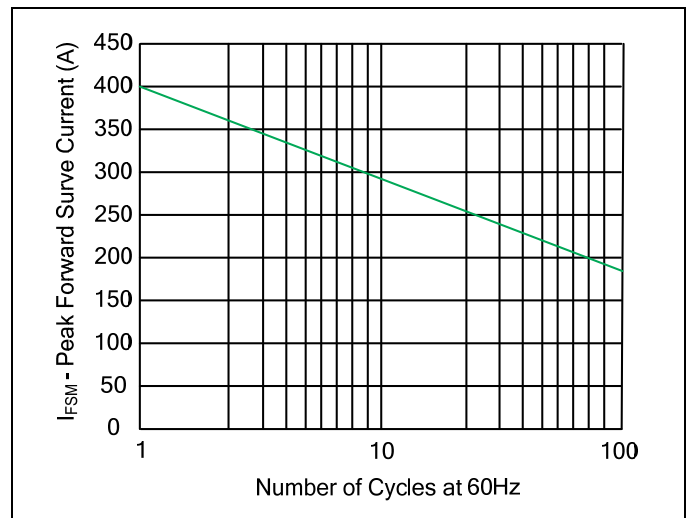

Figure 6. Maximum Non-Repetitive Forward Surge Current Uni-Directional Only



## Recommended Soldering Conditions

### Soldering Parameters

Reflow Condition		Lead-free assembly
Pre Heat	- Temperature Min ( $T_{s(min)}$ )	150°C
	- Temperature Max ( $T_{s(max)}$ )	200°C
	- Time (min to max) ( $t_s$ )	60 – 180 secs
Average ramp up rate (Liquidus Temp ( $T_A$ ) to peak)		3°C/second max
$T_{s(max)}$ to $T_A$ - Ramp-up Rate		3°C/second max
Reflow	- Temperature ( $T_A$ ) (Liquidus)	217°C
	- Time (min to max) ( $t_s$ )	60 – 150 seconds
Peak Temperature ( $T_p$ )		260 <sup>+0/-5</sup> °C
Time within 5°C of actual peak Temperature ( $t_p$ )		20 – 40 seconds
Ramp-down Rate		6°C/second max
Time 25°C to peak Temperature ( $T_p$ )		8 minutes Max.
Do not exceed		260°C

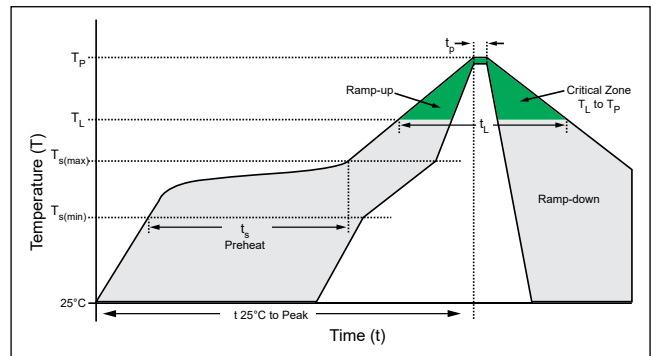

### Flow/Wave Soldering (Solder Dipping)

<b>Peak Temperature :</b>	265°C
<b>Dipping Time :</b>	10 seconds
<b>Soldering :</b>	1 time

### Physical Specifications

<b>Weight</b>	0.015oz., 0.4g
<b>Case</b>	JEDEC DO-204AC (DO-15) molded plastic body over passivated junction.
<b>Polarity</b>	Color band denotes the cathode except Bipolar.
<b>Terminal</b>	Matte Tin axial leads, solderable per JESD22-B102.

### Environmental Specifications

<b>High Temp. Storage</b>	JESD22-A103
<b>HTRB</b>	JESD22-A108
<b>Temperature Cycling</b>	JESD22-A104
<b>H3TRB</b>	JESD22-A101
<b>RSH</b>	JESD22-B106

### Dimensions

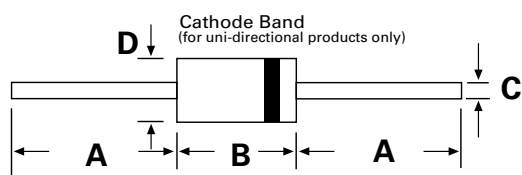

P600

Dimensions	Inches		Millimeters	
	Min	Max	Min	Max
A	1.000	-	25.40	-
B	0.340	0.360	8.60	9.10
C	0.048	0.054	1.22	1.36
D	0.340	0.360	8.60	9.10

**Part Numbering System**

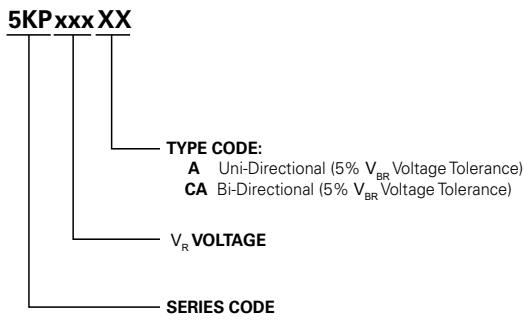

**Part Marking System**

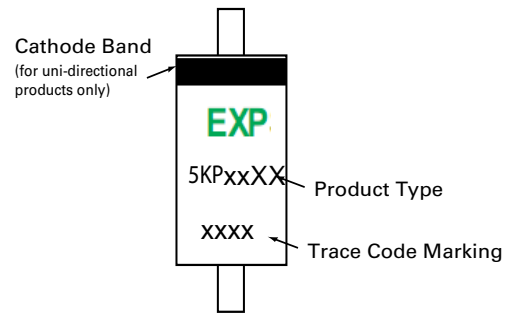

**Packing Options**

Part Number	Component Package	Quantity	Packaging Option	Packaging Specification
5KPxxxXX	P600	300	Tape & Reel	EIA STD RS-296

**Tape and Reel Specification**

Tape	Symbol	Dimension (mm)
	A	10.0±0.5
	B	53.0±1.0
	Z	1.2Max.
	T	6.0±0.4
	E	0.8Max.
	L1-L2	1.0Max.